

Miniature Bending Beam Load Cell

With mechanical overload protection

Model 8510

CAD data 2D/3D for this sensor:
Download directly at www.traceparts.com
Info: refer to data sheet 80-CAD-EN

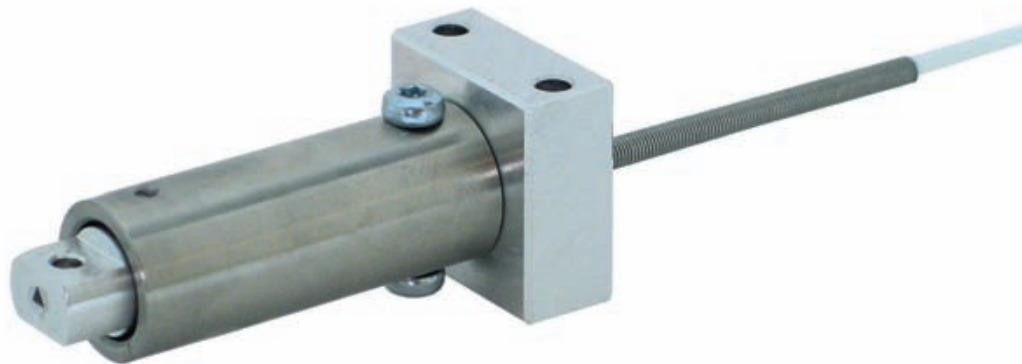

- For tension and compression forces
- Small measuring ranges from 0 ... 1 N to 0 ... 20 N
- Mechanical protection against overload up to quintuple range
- Compact size
- Easy installation
- Special design upon request

Application

The model 8510 bending beam load cell is suitable for measuring small and extremely small applied forces. The mechanical overload protection available for all measuring ranges prevents the sensor from being damaged by excessively high static and quasi-static loads which can occur during measurement and installation.

The sensor can be extended axially, e.g. by a finger, which does not influence the measuring.

Essential application of this sensor include measurement and testing of the following components:

- ▶ Switches (limit-, micro- and toggle-switches)
- ▶ Buttons
- ▶ Contact coupling and contact decoupling forces
- ▶ Frictional forces
- ▶ Spring characteristics
- ▶ Tension of wire and string windings

Description

The sensor element consists of a double bending beam with applied strain gauges.

Changes in the ohmic resistance of the strain gauge full-bridge caused by applied forces are converted into electrical voltages. The precise value (characteristic value) of the output voltage, resulting from the application of a rated force to the sensor, is specified in the accompanying calibration protocol.

The sensor has to be mounted by two screws on the cable side. The opposite is meant to receive applied forces (loads).

Once the rated stress or strain is exceeded by 20 %, further deflection of the bending beam is prevented by an integrated, mechanical stop. This protects the sensor element against permanent deformation.

8510 EN

Technical Data

Order Code	Measuring Range	Overload Protection up to	Natural Frequency	Weight [g]
8510-5001	0 ... 1 N	5 N	100 Hz	50
8510-5002	0 ... 2 N	10 N	150 Hz	50
8510-5005	0 ... 5 N	15 N	250 Hz	50
8510-5010	0 ... 10 N	20 N	300 Hz	50
8510-5020	0 ... 20 N	40 N	500 Hz	50

Electrical values

Bridge resistance:
full-bridge, foil type strain gauge 350 Ω, nominal*

Excitation:
measuring range 0 ... 1 N max. 3 V
measuring range 0 ... 2 N and above max. 5 V

Nominal value: 1 mV/V, nominal*

Insulation resistance: > 10 MΩ

Calibration resistance: 100 kΩ ± 0.1 %
The bridge output voltage resulting by a shunt of this value is specified in the calibration certificate.

* Deviations from the stated value are possible

Environmental conditions

Temperature operating: 15 °C ... 70 °C

Temperature compensated: - 20 °C ... 80 °C

Temperature effect zero: ≤ 0.03 % F.S./K

Temperature effect span: ≤ 0.03 % Rdg./K

Mechanical values

Measurement accuracy: ≤ ± 0.25 % F.S.

Combined values from non-linearity, hysteresis and non-repeatability.

Measurement type: compression and tension force

Preferential direction of measurement:
The direction of calibration is indicated by an arrow on the sensor. The output voltage will be positive, if a load is given in this direction.

Deflection (full scale): 0.15 mm, nominal

Maximum effective force:
mechanical stop at approx. 120 % of full scale.

Overload limits: see table

Dynamic performance: up to 50 % F.S.
(model 8510 is not qualified for a very large number of loadings.)

Material: sensor element: high-strength aluminium;
housing: high-grade steel shell.

Protection class: in accordance to EN 60529 IP20

Weight: see table

Electrical connection: shielded flexible cable, ø 2 mm, length 2 m, bending radius ≥ 20 mm, with kink-protection sleeve, ø 3 mm, length 40 mm

Wiring code:
white excitation positive
brown excitation negative
yellow signal output positive
green signal output negative

Installation Instructions

2 clearance holes designed to accommodate M3 screws are provided for mounting the sensor (refer to the drawing).

Forces are exerted on the opposite side. The hole on that side is meant for mounting a suitable force application device (e.g. a load knob).

The correct application of forces is of crucial importance for achieving a high measurement quality. It ensures that the measurement accuracy is not affected by lateral forces or moments.

Lateral forces and moments are produced mainly by eccentric and slanted loads.

Dimensional drawing model 8510

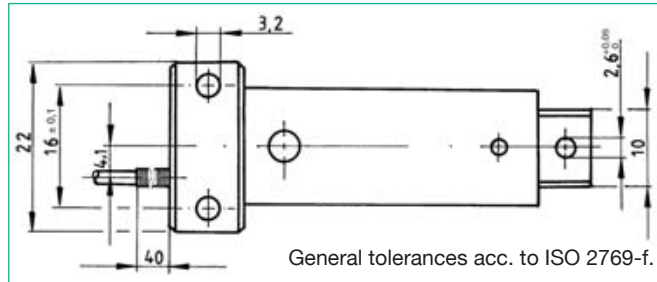
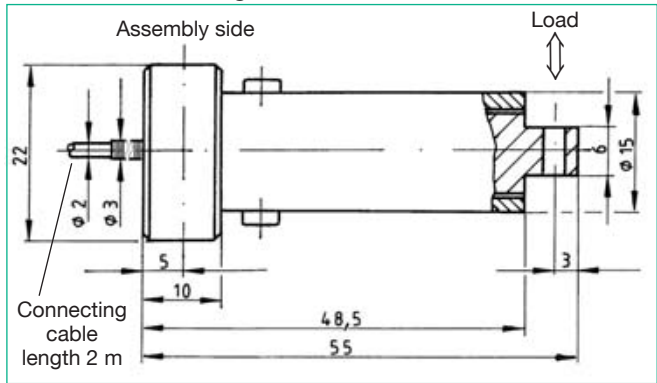

The CAD drawing (3D/2D) for this sensor can be imported online directly into your CAD system.
Download via www.burster.com or directly at www.traceparts.com.
For further information about the burster traceparts cooperation refer to data sheet 80-CAD-EN.

Order Information

Miniature bending beam load cell measuring range 0 ... 1 N
Model 8510-5001

Miniature bending beam load cell measuring range 0 ... 5 N
Standardization of the rated characteristic value to 1 mV/V
Model 8510-5005-V010

Accessories

Mating connector, 12 pin for burster desktop units except for 9163
Model 9941

Mating connector, 9 pin, for 9163-V3, 9235 and 9310
Model 9900-V209

Mounting of mating connector to conductor cable for general use in preferential direction (positive measuring signal in preferential direction)
Order Code 99004

Against preferential direction (positive measuring signal against preferential direction)
Order Code 99007

Force simulator model 9405 refer to data sheet 76-9405 in section 7.
(replaces the sensor for checking the amplifier or the indicator)

Supply devices, amplifiers and process monitoring units, such as the model 9243 module amplifier and model 9180 digital display and In-line amplifier model 9235
see section 9 of the catalog.

Test and calibration protocol

Protocol with traceability certificate and indication of the zero signal, the characteristic and the calibration step is included in scope of delivery.

Option

Standardization of the rated characteristic value in the connection cable to 1 mV/V ± 0.25 %
Order code: V010
(The standardization, length 70 mm, diameter approx. 8 mm, is integrated in the cable, approx. 30 mm before the cable end.)

Manufacturer Calibration Certificate (WKS)

Load cell or load cell with measurement device (amplifier, display)
Calibration up / down in 20 % increments and in fitting position.