

Torque Sensor

Rotating, contact ring transfer

Model 86403 with square end

Model 86413 with round shaft ends

Model 86423 with hexagonal shaft end



CAD data 2D/3D for this sensor:
Download directly at www.traceparts.com
Info: refer to data sheet 80-CAD-EN



Model 86403



Model 86413



Model 86423

NEW
Measurement ranges from 0 ... 1 Nm

- Measuring ranges between 0 ... ± 1 Nm and 0 ... 1000 Nm
- Excellent reproducibility
- Standardized output signal makes exchange easy
- Optionally available with factory calibration certificate
- Designed for clockwise and counterclockwise torque
- Optionally available with integrated angle measurement
- Rotation speed up to 3000 min⁻¹/min (short-term)

Application

Precise, reliable measurements of both static and dynamic torques in either direction can be made with this range of sensors.

This opens a wide range of possible applications to the user. These torque sensors are standard equipment in a wide range of industrial automation, quality control and automotive components industry applications, as well as in laboratories.

Typical applications:

Screwing technology

- ▶ Checking and adjusting bolting tools such as torque limiting wrenches, screwdrivers
- ▶ Testing bolted connections

Measuring the drag torque of motors and pumps

- ▶ Frictional torques of gears, bearings and seals
- ▶ Testing torsion springs
- ▶ Adjusting equipment in the automobile industry (sunroof, power windows etc.)

Description

Strain gauges are mounted on the torsion shaft of the sensor element, itself made of steel, connected to form a full bridge. The electrical power excitation for the wire strain gauge full bridge and the transmission of the measured signal is provided through a high-quality slip-ring system between the stator and the rotor.

For a clockwise torque, the measurement signal is positive, and it is negative for a counterclockwise torque.

The sensor for the optionally available angle measurement for the square shaft versions is fitted with an additional pulse-generating disk.

With the aid of a second encoder track, displaced by 90°, allows the subsequent evaluation units to perform 4-fold edge evaluation. This allows significantly improved resolution to be achieved. The offset track makes it possible to detect the direction of the rotation.

The characteristic parameters for the sensors are standardized in order to reduce the effort required to check a connected amplifier or to exchange the sensor.

Technical Data

Model 86403

Torque sensor, rotating, standard square ends according to DIN 3121

Order Code	Measurement Range	Sensitivity [mV/V]	Square Ends	Spring Constant [Nm/rad]	Max. Lateral Force [N]	Torque of Inertia Drive End J in [kg m ²]	Mass [kg]	Dimensions [mm]													
								A	B	C	D	E	F	G	H	L	K	M	N	P	Q
86403-5001	0 ... ± 1 Nm	0.5	1/4"	1.9·10 ²	4	2.9·10 ⁻⁷	0.14	45.5	13	8.6	8	64	7.2	9.9	39	24	12	5	9	8.6	12.2
86403-5002	0 ... ± 2 Nm	0.5	1/4"	4.3·10 ²	5	2.9·10 ⁻⁷	0.14	45.5	13	8.6	8	64	7.2	9.9	39	24	12	5	9	8.6	12.2
86403-5005	0 ... ± 5 Nm	2	1/4"	2.7·10 ²	7	2.9·10 ⁻⁷	0.14	45.5	13	8.6	8	64	7.2	9.9	39	24	12	5	9	8.6	12.2
86403-5012	0 ... ± 12 Nm	2	1/4"	6.6·10 ²	7.5	3.0·10 ⁻⁷	0.14	45.5	13	8.6	8	64	7.2	9.9	39	24	12	5	9	8.6	12.2
86403-5025	0 ... ± 25 Nm	2	3/8"	2.3·10 ³	12	1.2·10 ⁻⁵	0.32	47.5	22	10.1	12.2	71	10.4	13.5	54	42	21	6	9.5	11	10.5
86403-5063	0 ... ± 63 Nm	2	3/8"	5.7·10 ³	28	1.2·10 ⁻⁵	0.32	47.5	22	10.1	12.2	71	10.4	13.5	54	42	21	6	9.5	11	10.5
86403-5160	0 ... ± 160 Nm	2	1/2"	1.4·10 ⁴	65	1.7·10 ⁻⁵	0.35	47.5	29.7	10.7	15.9	76	15.1	17.9	54	42	21	6	9.5	11	10.5
86403-5500	0 ... ± 500 Nm	2	3/4"	5.9·10 ⁴	200	1.1·10 ⁻⁴	0.80	55	44	19.1	24.9	100	22.6	25.9	68	60	30	-	-	-	10.5
86403-6001	0 ... ± 1000 Nm	2	1"	1.1·10 ⁵	240	2.6·10 ⁻⁴	1.40	55	54	33.1	29.6	132	27.4	43.9	68	60	30	-	-	-	10.5

Higher ranges on request

Dimensional drawing Model 86403

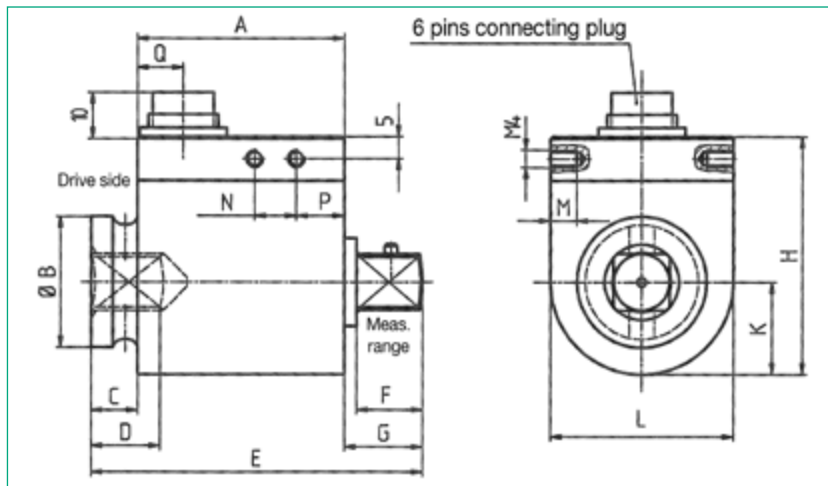

Model 86403-...-V501

Torque sensor, rotating, standard square ends, with angle measurement

Order Code	Measurement Range	Sensitivity [mV/V]	Square Ends	Spring Constant [Nm/rad]	Max. Lateral Force [N]	Torque of Inertia Drive End J in [kg m ²]	Mass [kg]	Dimensions [mm]																	
								A	B	C	D	E	F	G	H	L	K	M	N	P	Q	R	S		
86403-5001-V501	0... ± 1 Nm	0.5	1/4"	1.4 · 10 ²	4	3.2 · 10 ⁻⁶	0.5	65	13	9	8	84	7.2	10	48.5	34	17	4	9	10.5	30.5	10	12		
86403-5002-V501	0... ± 2 Nm	0.5	1/4"	4.5 · 10 ²	5	3.3 · 10 ⁻⁶	0.5	65	13	9	8	84	7.2	10	48.5	34	17	4	9	10.5	30.5	10	12		
86403-5005-V501	0... ± 5 Nm	2	1/4"	3.0 · 10 ²	7	3.3 · 10 ⁻⁶	0.5	65	13	9	8	84	7.2	10	48.5	34	17	4	9	10.5	30.5	10	12		
86403-5012-V501	0... ± 12 Nm	2	1/4"	6.7 · 10 ²	7.5	3.3 · 10 ⁻⁶	0.5	65	13	9	8	84	7.2	10	48.5	34	17	4	9	10.5	30.5	10	12		
86403-5025-V501	0... ± 25 Nm	2	3/8"	2.4 · 10 ³	12	1.2 · 10 ⁻⁵	0.5	78	22	11	12.2	100.8	10.4	11.8	57	42	21	6	50	16	28	24	9		
86403-5063-V501	0... ± 63 Nm	2	3/8"	6.8 · 10 ³	28	1.2 · 10 ⁻⁵	0.5	78	22	11	12.2	100.8	10.4	11.8	57	42	21	6	50	16	28	24	9		
86403-5160-V501	0... ± 160 Nm	2	1/2"	1.2 · 10 ⁴	65	1.7 · 10 ⁻⁵	0.6	78	29.8	12	16.9	106	15.1	16	57	42	21	6	50	16	28	24	9		
86403-5500-V501	0... ± 500 Nm	2	3/4"	3.9 · 10 ⁴	200	9.2 · 10 ⁻⁵	1.3	92	44	18	24.9	135	22.6	25	70	56	28	10	66	13	43	24	16		
86403-6001-V501	0... ± 1000 Nm	2	1"	8.9 · 10 ⁴	240	3.6 · 10 ⁻⁴	1.5	92	54	53.1	29.9	177	27.3	31.9	70	56	28	10	66	13	43	24	16		

Dimensional drawing Model 86403-...V501

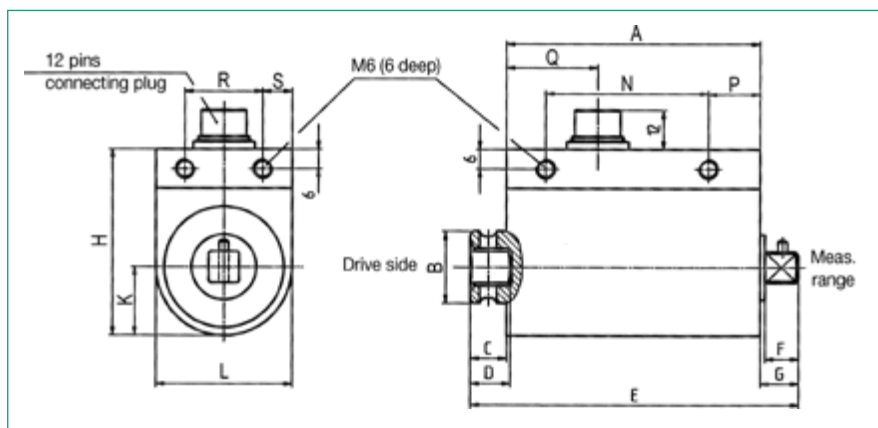

Technical Data

Model 86413

Torque sensor, rotating, round shaft ends with parallel key

Order Code	Measurement Range	Sensitivity	Spring Constant	Max. Lateral Force	Torque of Inertia Drive End	Mass	Dimensions [mm]													
							[mV/V]	[Nm/rad]	[N]	J in [kg m ²]	[kg]	A	B	C	D	E	G	H	L	K
86413-5001	0 ... ± 1 Nm	0.5	1.9 · 10 ²	4	1.34 · 10 ⁻⁶	0.16	45.5	8	19.7	18	85	19.7	39	24	12	5	9	27.9	33.3	5
86413-5002	0 ... ± 2 Nm	0.5	1.9 · 10 ²	5	1.34 · 10 ⁻⁶	0.16	45.5	8	19.7	18	85	19.7	39	24	12	5	9	27.9	33.3	5
86413-5005	0 ... ± 5 Nm	2	2.43 · 10 ²	7	1.34 · 10 ⁻⁶	0.16	45.5	8	19.7	18	85	19.7	39	24	12	5	9	27.9	33.3	5
86413-5010	0 ... ± 10 Nm	2	4.56 · 10 ²	7.5	1.35 · 10 ⁻⁶	0.16	45.5	8	19.7	18	85	19.7	39	24	12	5	9	27.9	33.3	5
86413-5020	0 ... ± 20 Nm	2	1.77 · 10 ³	12	1.16 · 10 ⁻⁵	0.35	47.5	15	21.1	20	90	21.5	54	42	21	6	9.5	11	10.5	5
86413-5050	0 ... ± 50 Nm	2	4.82 · 10 ³	28	1.17 · 10 ⁻⁵	0.38	47.5	15	21.1	20	90	21.5	54	42	21	6	9.5	11	10.5	5
86413-5100	0 ... ± 100 Nm	2	9.85 · 10 ³	65	1.25 · 10 ⁻⁵	0.42	47.5	18	24	22	95	23.6	54	42	21	6	9.5	11	10.5	5
86413-5200	0 ... ± 200 Nm	2	2.80 · 10 ⁴	80	9.15 · 10 ⁻⁵	0.90	55	32	41.6	40	140	43.4	68	60	30	-	-	-	10.5	5
86413-5500	0 ... ± 500 Nm	2	6.33 · 10 ⁴	200	9.42 · 10 ⁻⁵	0.90	55	32	41.6	40	140	43.4	68	60	30	-	-	-	10.5	5

Dimensional drawing Models 86413 and 86413-...V501

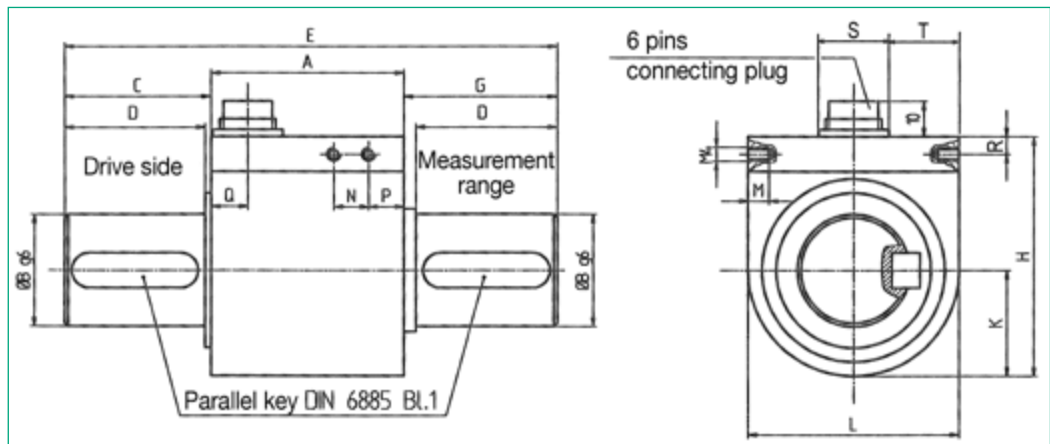

Model 86413-...V501

Torque sensor, rotating, round shaft with keyways and internal angle measurement

Order Code	Measurement Range	Sensitivity	Spring Constant	Max. Lateral Force	Torque of Inertia Drive End	Mass	Dimensions [mm]														
							[mV/V]	[Nm/rad]	[N]	J in [kg m ²]	[kg]	A	B	C/G	D	E	H	L	K	M	N
86413-5001-V501	0 ... ± 1 Nm	0.5	2.3 · 10 ²	4	3.3 · 10 ⁻⁶	0.5	65	10	17.5	15.5	100	48.5	34	17	4	9	10.5	30.5	6.5	20	7
86413-5002-V501	0 ... ± 2 Nm	0.5	2.3 · 10 ²	5	3.3 · 10 ⁻⁶	0.5	65	10	17.5	15.5	100	48.5	34	17	4	9	10.5	30.5	6.5	20	7
86413-5005-V501	0 ... ± 5 Nm	2	2.9 · 10 ²	7	3.3 · 10 ⁻⁶	0.5	65	10	17.5	15.5	100	48.5	34	17	4	9	10.5	30.5	6.5	20	7
86413-5010-V501	0 ... ± 10 Nm	2	5.6 · 10 ²	7.5	1.1 · 10 ⁻⁵	0.5	65	10	17.5	15.5	100	48.5	34	17	4	9	10.5	30.5	6.5	20	7
86413-5020-V501	0 ... ± 20 Nm	2	1.6 · 10 ³	12	1.1 · 10 ⁻⁵	0.6	78	15	21	20	120	57	42	21	6	50	16	28	6	20	11
86413-5050-V501	0 ... ± 50 Nm	2	4.1 · 10 ³	28	1.1 · 10 ⁻⁵	0.6	78	15	21	20	120	57	42	21	6	50	16	28	6	20	11
86413-5100-V501	0 ... ± 100 Nm	2	7.9 · 10 ³	65	1.3 · 10 ⁻⁵	0.6	78	18	25	24	128	57	42	21	6	50	16	28	6	20	11
86413-5200-V501	0 ... ± 200 Nm	2	2.8 · 10 ⁴	80	1.0 · 10 ⁻⁴	1.3	92	32	44	40	180	70	56	28	10	66	13	43	6	20	18
86413-5500-V501	0 ... ± 500 Nm	2	5.3 · 10 ⁴	200	1.0 · 10 ⁻⁴	1.3	92	32	44	40	180	70	56	28	10	66	13	43	6	20	18

Model 86423

Torque sensor, rotating, standard hexagonal shaft ends 1/4" DIN 3126 Form E/F

Order Code	Measurement Range	Sensitivity	Mass
		[mV/V]	[kg]
86423-5001	0 ... ± 1 Nm	0.5	0.2
86423-5002	0 ... ± 2 Nm	1	0.2
86423-5005	0 ... ± 5 Nm	1	0.2
86423-5010	0 ... ± 10 Nm	2	0.2
86423-5020	0 ... ± 20 Nm	2	0.2

Dimensional drawing Model 86423

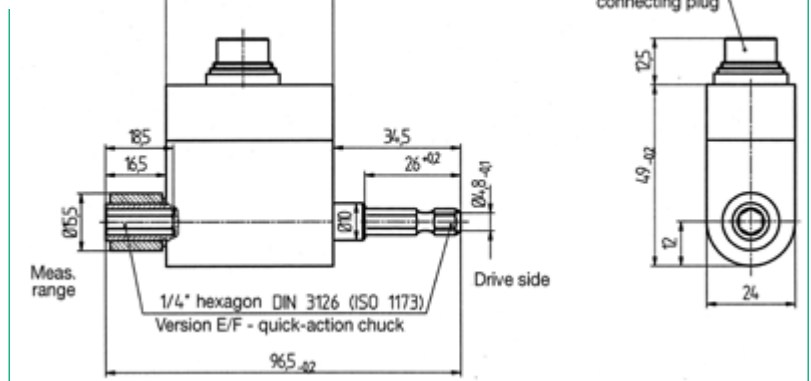

The CAD drawing (3D/2D) for this sensor can be imported online directly into your CAD system.

Download via www.burster.com or directly at www.traceparts.com. For further information about the burster traceparts cooperation refer to data sheet 80-CAD-EN.

- ▶ Drive end --- hexagon head
- ▶ Measurement side --- hexagon socket
- ▶ Quick-action chuck

Note: The max. allowed static lateral force is smaller than 10 % of the lower value of the measurement range.

General Technical Data for all Sensors

Electrical values

Torque sensor

Bridge resistance (full bridge):	350 Ω
Excitation voltage:	2 ... 12 V DC
Characteristic:	standardized 0.5 mV/V, 1mV/V or 2 mV/V (refer to tables)
Tolerance of characteristic:	± 0.1 %

Test (option):

If the full bridge is connected to the positive strain gauge excitation voltage, it generates an electrical signal equivalent to 100 % of the nominal signal.

Angle displacement sensor (refer to options)

Excitation voltage:	5 V DC
Angle displacement measurement:	360 pulses/rotation
2 TTL outputs with two encoders, angle displacement 90° for detection of direction.	

Environmental conditions

Range of operation temperature:	±10 °C ... + 60 °C
Range of nominal temperature:	± 5 °C ... + 50 °C
Influence of temperature in range of nominal temperature:	
to zero signal	±0.01 % F.S./K
to characteristic	±0.003 % Rdg./K

Mechanical values

Measurement error, consisting of non-linearity and hysteresis	≤ ± 0.1 % F.S.
Relative spread in unchanged mounting position:	≤ ± 0.05 % F.S.
Range of rotation:	
an exceedance of the max. rotary speed, up to 1.5 x max. rotary speed, is possible only for short time	

max. rotary speed for

ranges from von	≤ 0 ... 12 Nm	2000'/min
ranges from	0 ... 25 Nm to 0 ... 160 Nm	1500'/min
ranges from	0 ... 500 Nm to 0 ... 1000 Nm	1000'/min
ranges from	0 ... 2000 Nm to 0 ... 5000 Nm	500'/min

Max. operation torque:	120 % of nominal torque
Dynamic torques (peak-peak):	max. 70 % of nominal torque
Limit torque (static):	130 % of nominal torque
Breakaway torque (static):	250 % of nominal torque
Angle displacement at nominal torque:	< 0.5 °

Material: high strength heat-treated steel, similar to 1.2826 or 12738

Protection class: acc. to EN 60529 IP50

Dimensions: refer to table and dimensional drawing

Maintenance/cleaning (contact ring abrasion, recommended change of the brushes): after approx. 5×10^7 rotations

Mechanical connection:

model 86403	Internal and external square acc. to DIN 3121, used for connection to assembling tools for bolt and nuts.
model 86413	Version with keyways on both shaft ends (2 x 180 °) acc. to DIN 6885 page 1
model 86423	Hexagon head and socket 1/4", acc. to DIN 3126 (ISO 1173) version E/F quick-action chuck

Electrical connection:

Sensors without measurement of angle displacement
6 pin plug-in connection Mating connector model 9953

Wiring:

1	excitation	negative	
2	excitation	positive	
3	shield (not connected in the sensor)		
4	output	positive	for clockwise torques
5	output signal	negative	for clockwise torques
6	100 % check		

Sensors with measurement of angle displacement

12 pin plug-in connection Mating connector model 9940

Wiring:

A	excitation	negative for torque	(0 V DC)
B	excitation	positive for torque	(2 ... 12 V DC)
C	output signal	positive for clockwise torque	
D	output signal	negative for clockwise torque	
E	excitation	negative for angle displ.	(0 V DC)
F	excitation	positive for angle displ.	(+ 5 V DC)
G	angle output 1	(TTL pulses)	
H	angle output 2	(TTL pulses)	
J	angle output		(0 V DC)
K	check, shunt calibration (option)		
L	NC		
M	shield		

Order Information

- Torque sensor, rotating, square end measurement range 0 ... 1 Nm **Model 86403-5001**
- Torque sensor, rotating, square end, with meas. of angle displ. measurement range 0 ... 63 Nm **Model 86403-5063-V501**

Accessories

for sensors without measurement of angle displacement

Mating connector 6 pin, in scope of delivery	Model 9953
Mating connector 6 pin, 90° outlet	Model 9900-V589
Connection cable, one end open, length 3 m	Model 99553-000A-0110030
Connection cable to burster desktop devices with 12 pin panel jack, length 3 m	Model 99141-553A-0150030
Connection cable to 9235 and 9310 length 3 m	Model 99209-553A-0110030
Cable adapter to 9163-V3XXXX length 0.2 m	Model 99209-609A-0090002

for sensors with measurement of angle displacement

Mating connector 12 pin, in scope of delivery	Model 9940
Mating connector 12 pin, 90° outlet	Model 9900-V539
Connection cable, one end open, length 3 m	Model 99540-000K-0270030
Connection cable to model 9306, length 3 m	Model 99141-540K-0270030

Strain gauge simulator

Model 9405

The sensor will be replaced by the strain gauge simulator for checking amplifiers or indicators.

Supply units, amplifiers and process control units like modular amplifiers models 9243, 9205, 9163 or 9306

refer to section 9 of the catalog.

Options

Higher measurement ranges on request.

Manufacturers Calibration Certificate (WKS)

Calibration of a torque sensor with or without amplifier / indicator (measurement chain) in clockwise or / and counter clockwise direction in increments of 20 % of the measurement range.

Mounting Instructions

The sensors, particularly those with small measuring ranges, must be mounted carefully. It is important that the drive and measuring ends are not reversed during assembly. The slip-ring rotation transmitter is located on the drive side. If fitted incorrectly (measuring side and drive side swapped), its friction, which is unavoidable, will be included in the measurement.

The correct position of the measuring side is indicated on the corresponding dimensional drawing. The measuring shaft should always be cleaned prior to assembly and should be supported during fitting, to ensure that no foreign objects are sticking to it. It is recommended that the sensor is electrically connected and that the output signal is watched at the time of fitting. Vibrations originating in the equipment should be kept away from the sensor. The sensor should only be mounted on the coupling after the parts have been accurately aligned. This should be done without free play or lateral forces. It is recommended that the cable connection points upwards, so that abrasion dust cannot fall onto the brush connections.