



Precision Torque Sensor

Non-contact transmission for rotating applications

Optional measurement of angle and speed

Model 8661



Optional:

- ▶ Refresh rate 1000 measurements/s
- ▶ USB interface plus free LabVIEW driver
- ▶ Dual range

- Measuring range 0 ... 0,02 N-m to 0 ... 1000 N-m
- Clockwise and counter-clockwise torque
- Low linearity deviation of $\leq \pm 0.05$ % F.S.
- Intelligent operating state indicator
- 16 bit D/A- converter including digital adjustment
- Output signal 0 ... ± 10 V (optional 0 ... ± 5 V or USB)
- Speed and angle measurement with resolution of up to 2000 increments (option)
- High performant software (option USB) including mechanical power computation, multichannel operation, freely editable mathematical auxiliary channel
- Excellent price-performance ratio

Application

The 8661 precision torque sensor is the ideal choice for reliable measurement of static and dynamic clockwise and counter-clockwise torques. Thanks to its high measurement quality and low linearity error, the sensor is equally at home in quality control or research & development. Designed for non-contact operation and zero-maintenance, the 8661 is also ideally suited to the production environment, whether on shift-based production lines, test benches or end-of-line test systems. The 8661 torque sensor is the specialist device for constant torque measurements during continuous operation and for test-bench measurements of holding, friction, break-away or tightening torques.

An optional built-in incremental encoder disk with up to 2000 increments makes the sensor the perfect alternative where space or budget rule out an additional angle or speed sensor. For mobile use and for instant digital access to measurement data, the 8661 torque sensor is also available with a USB interface. A laptop or PC running the DigiVision PC software can read, visualize and archive the measurement data. System integration, for instance into LabView, is easy thanks to a driver package available free of charge.

- ▶ Test setups for precision mechanics
- ▶ Haptics testing of actuator elements
- ▶ Engine test benches and power measurement
- ▶ Biomechanical product testing
- ▶ Measurement of bearing friction torques
- ▶ Suitable for use in all types of test bench

Description

The 8661 torque sensor essentially consists of three blocks: the rotor, the housing (containing the stator) and the output electronics. The rotor is composed of several parts and contains the actual measuring device - a spring element. This spring element is designed to deform elastically under an applied torque. This results in torsion, which in turn produces a very small amount of strain in the material of the measuring element. Within certain limits, this strain is linear and proportional to the applied torque. It can be measured using strain gauges, which are connected in a Wheatstone bridge circuit. A microprocessor conditions the signal from the Wheatstone bridge and transfers it to the stator. The rotor is linked to the stator via two ball-bearings, and signal transfer is contactless. The stator contains the electronics needed to supply the rotor with the required operating voltage by inductive and contactless means. In the opposite direction, it receives the optically transmitted, digitized torque signal and routes this signal to the output electronics. Here it is converted into an analog 0... ± 10 V output signal, which is output via the connector. Alternatively, the sensor is available with a USB port. The 8661 torque sensor can optionally be fitted with an incremental encoder disk for measuring the speed and angle. This disk has 2000 increments, allowing angular resolutions of up to 0.045° by means of four-edge decoding. Three LEDs indicate the sensor operating status for simple diagnostics. Speeds of up to 25,000 min⁻¹ can be measured depending on the selected measurement range and optional incremental encoder disk.

8661 EN

Technical Data
Table 1

Order Code	L2	L3	L4	B1	H	H1	D1	D2	D3	D4		A1	A2	A3	T1		T2		A4	A5	N1	N2	N3
										Ø	deep				deep	deep							
8661-4020-VXXXX	10	66	11	40	60	15	5	8	29	3.1	5	45	31	30	M4	8	M3	5,5	26	24	1.5	0	0
8661-4050-VXXXX	10	66	11	40	60	15	5	8	29	3.1	5	45	31	30	M4	8	M3	5,5	26	24	1.5	0	0
8661-4100-VXXXX	10	66	11	40	60	15	5	8	29	3.1	5	45	31	30	M4	8	M3	5,5	26	24	1.5	0	0
8661-4200-VXXXX	10	66	11	40	60	15	5	8	29	3.1	5	45	31	30	M4	8	M3	5,5	26	24	1.5	0	0
8661-4500-VXXXX	10	66	11	40	60	15	5	8	29	3.1	5	45	31	30	M4	8	M3	5,5	26	24	1.5	0	0
8661-5001-VXXXX	10	66	11	40	60	15	5	8	29	3.1	5	45	31	30	M4	8	M3	5,5	26	24	1.5	0	0
8661-5002-VXXXX	14	66	14	40	60	15	6	8	29	3.1	5	45	31	30	M4	8	M3	5,5	26	24	1.5	0	0
8661-5005-VXXXX	30	83	30	55	85	27.5	15	15	54	3.1	5	57	44	41	M5	9	M4	6	45.3	45.3	1.5	0	0
8661-5010-VXXXX	30	83	30	55	85	27.5	15	15	54	3.1	5	57	44	41	M5	9	M4	6	45.3	45.3	1.5	0	0
8661-5020-VXXXX	30	83	30	55	85	27.5	15	15	54	3.1	5	57	44	41	M5	9	M4	6	45.3	45.3	1.5	0	0
8661-5050-VXXXX	45	78	45	64	94	32	26	26	58.5	3.1	5	57	44	41	M5	8	M4	6	54.4	54.4	3	3	0
8661-5100-VXXXX	45	78	45	64	94	32	26	26	58.5	3.1	5	57	44	41	M5	8	M4	6	54.4	54.4	3	3	0
8661-5200-VXXXX	45	78	45	64	94	32	26	26	58.5	3.1	5	57	44	41	M5	8	M4	6	54.4	54.4	3	3	0
8661-5500-VXXXX	95	95	95	107	137	53,5	45	45	97	4.1	10	50	90	30	M8	20	M6	10	88.4	88.4	2.5	2.5	1,25
8661-6001-VXXXX	95	95	95	107	137	53,5	45	45	97	4.1	10	50	90	30	M8	20	M6	10	88.4	88.4	2.5	2.5	1,25

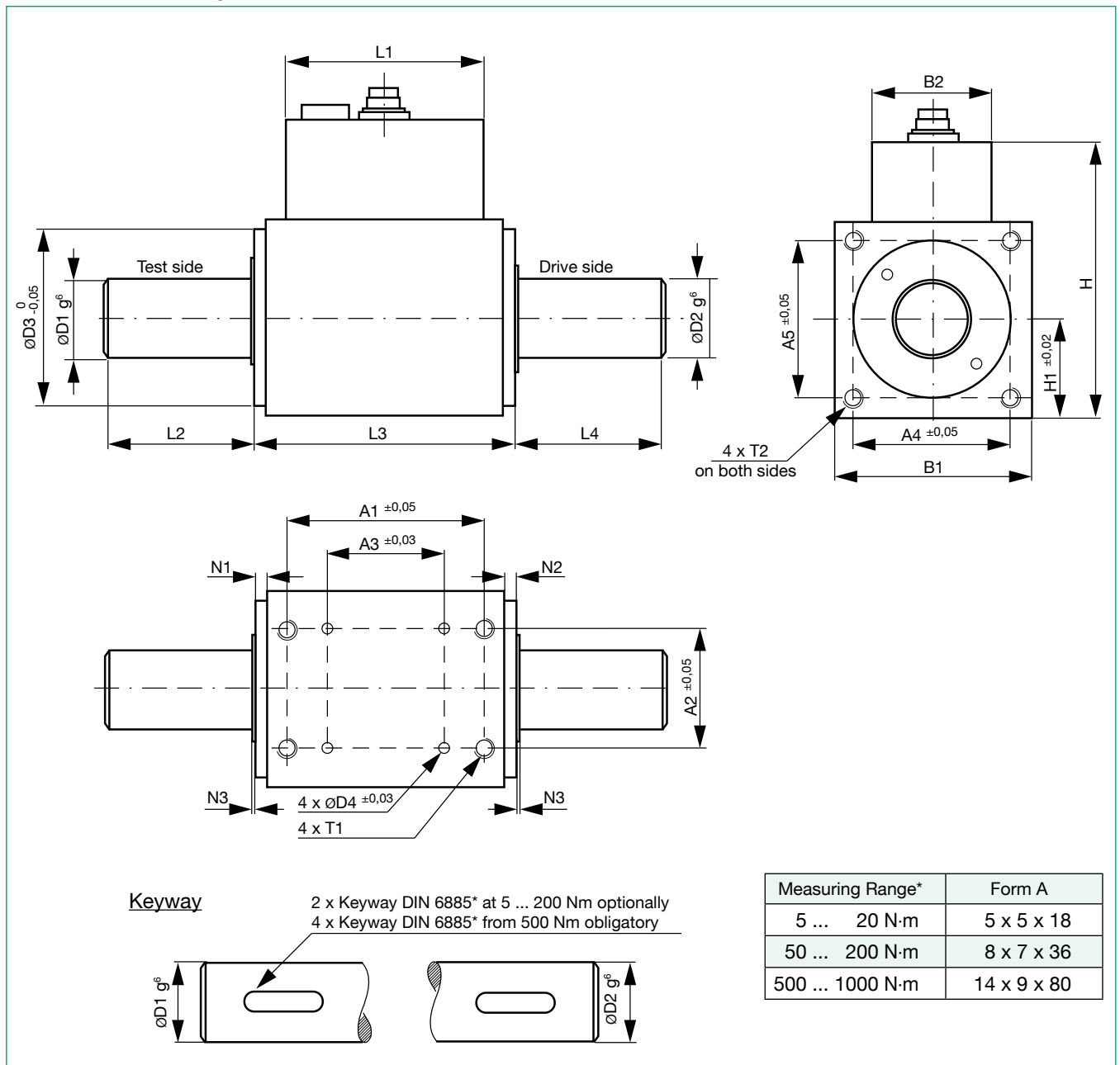
Dimensional drawing

Specifications, based on measurement range Table 2

Order Code	Measurement Range [N·m]	Spring Constant [N·m/rad]	Mass Moment of Inertia Drive Side [10 ⁻⁶ kg·m ²]	Mass Moment of Inertia Measuring Side [10 ⁻⁶ kg·m ²]	Maximum Permissible Axial Load* [N]	Maximum Permissible Radial Load [N]	Weight [g]	Max. Rotary Speed** [min ⁻¹]
8661-4020-V0XXX	0 ... ± 0.02	10	2.2	0.048	50	3	300	25 000
8661-4050-V0XXX	0 ... ± 0.05	10	2.2	0.048	50	3	300	25 000
8661-4100-V0XXX	0 ... ± 0.1	20	2.2	0.048	50	3	300	25 000
8661-4200-V0XXX	0 ... ± 0.2	50	2.2	0.05	50	3	300	25 000
8661-4500-V0XXX	0 ... ± 0.5	100	2.2	0.06	50	4	300	25 000
8661-5001-V0XXX	0 ... ± 1	100	2.2	0.062	50	7	300	25 000
8661-5002-V0XXX	0 ... ± 2	180	2.2	0.077	50	13	300	25 000
8661-5005-V0XXX	0 ... ± 5	800	14.3	2.2	200	15	900	15 000
8661-5010-V0XXX	0 ... ± 10	1700	14.3	2.35	200	30	900	15 000
8661-5020-V0XXX	0 ... ± 20	3000	14.6	2.6	200	60	900	15 000
8661-5050-V0XXX	0 ... ± 50	14000	85.7	33.30	300	125	1500	15 000
8661-5100-V0XXX	0 ... ± 100	25000	85.9	33.70	300	215	1500	15 000
8661-5200-V0XXX	0 ... ± 200	40000	87.5	35.00	300	215	1500	15 000
8661-5500-V0XXX	0 ... ± 500	150000	1200	600.00	500	250	6000	7000
8661-6001-V0XXX	0 ... ± 1000	220000	1200	600.00	500	500	6000	7000

* Maximum permitted axial load avoiding irreversible damage to the sensor. The measurement signal may vary under axial load.

** Max speed with option angle and speed measurement refer to page 5.

Dual-range torque sensor model

The sensor with two measuring ranges has the same dimensions as the standard version but it also has two different calibrated measuring ranges.

The dual range sensor offers significant advantages:

1. With a single sensor a very wide range of torques can be measured accurately.
2. Good overload protection particularly in smaller measuring ranges: For the smaller measuring range the sensor provides the overload protection of the larger measuring range.
3. No retooling time at all and only one coupling pair is needed.

Possible ratio of dual ranges sensor:

- ▶ 1:4
- ▶ 1:5
- ▶ 1:10

With the sensor with the 12 pin connector the measuring range is switched by applying a voltage level whose magnitude and whose ground reference correspond to the control signal. (For measuring range 1:1, 0 ... 3 V, for the extended measuring range 10 ... 30 V).

With the USB sensor, the measurement range is changed via the DigiVision software. The switching time is < 50 ms.

Typical applications of the dual range sensor are:

- ▶ Test stands for motors, turbines and gears, extruders
- ▶ Engineering
- ▶ Drive engineering
- ▶ Aeronautics and space sector
- ▶ Automotive
- ▶ Product development
- ▶ Quality assurance

Specification, based on measurement range Table 3

Order Code	Upper Range Value [N·m]	Measuring Range Extension End Value Second Range		
		1:4	1:5	1:10
see page 6 "Order Code"	0 ... 0.5	-	0.1 N·m	-
	0 ... 1	-	0.2 N·m	-
	0 ... 2	0.5 N·m	-	0.2 N·m
	0 ... 5	-	1 N·m	0.5 N·m
	0 ... 10	-	2 N·m	1 N·m
	0 ... 20	5 N·m	-	2 N·m
	0 ... 50	-	10 N·m	5 N·m
	0 ... 100	-	20 N·m	10 N·m
	0 ... 200	50 N·m	-	20 N·m
	0 ... 500	-	100 N·m	50 N·m
	0 ... 1000	-	200 N·m	100 N·m

Torque Sensor with integrated USB Interface (option)

- Includes powerful data acquisition software DigiVision
- Plug & Measure
- Numerical and graphical display of torque/speed/mechanical power as well as editable mathematical factors/results, etc.
- Suitable for mobile use with a notebook
- Power supply via the USB-port
- DLL and LabVIEW driver for free

This sensor version has an USB-port instead of the 0 ... ± 10 V output. This allows a PC-based evaluation of the measurement signals.

Beside torque, speed or angular displacement measurement values are provided optionally. The DigiVision software displays the mechanical power values also calculated by the sensor.



Configuration and Evaluation Software DigiVision

Multichannel configuration and evaluation software suitable for easy PC-based analysis and reporting in mobile and stationary applications field such as lab, R & D and industrial environment.

DigiVision Features

- ▶ Numerical and chart representation of the torque, speed, angle and mechanical power
- ▶ Automatic sensor detection
- ▶ Start and stop trigger features
- ▶ 4 limits per channel configurable
- ▶ Peak value memory for MIN/MAX
- ▶ Auto scale
- ▶ Storage function of the measuring log as Excel or PDF file
- ▶ Archive viewer including curve array display
- ▶ Multichannel operation with full version possible also with other sensors, e.g. 8625, 9206

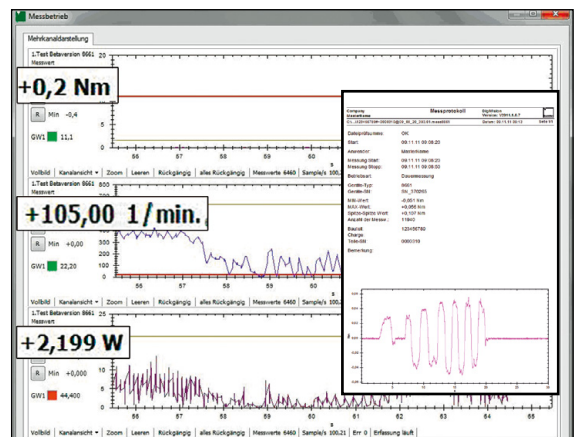

Screenshot P001: Multichannel display of a single sensor, below right: printed measuring reco

Operating System requirements

Windows 2000, XP, Vista, Windows 7, Windows 8 und Windows 10

DigiVision software as an add-on tool:

DigiVision 8661-P001 (supplied as standard)

- For one sensor (includes torque, speed and angle)
- Mechanical power calculation
- Up to 200 measured values per second
- Includes 8661-Z010 USB cable

DigiVision 8661-P100

Same features as 8661-P001, plus:

- Can handle up to 16 channels (sensors)
- Up to 1000 measured values per second, depending on sensor model

DigiVision 8661-P200

Same features as 8661-P001, plus:

- Can handle up to 32 channels (sensors)
- Up to 1000 measured values per second, depending on sensor model
- Additional user-configurable mathematical channels

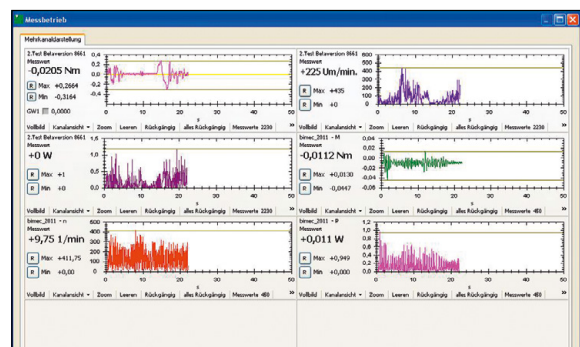

Screenshot P100: Multichannel display of two sensors, torque / speed / mechanical power

Torque sensor with integrated rotational speed / angular displacement measurement (option)

8661 torque sensors are optionally available with integrated rotational speed and angular displacement measurement. Two pulse channels – channel A and channel B – are always available.

For clockwise rotation (looking at the drive end), channel A leads channel B with a phase shift of 90°.

Only one pulse channel is needed for speed measurement.

For angular displacement measurement (or direction detection), both channels need to be evaluated. To achieve the maximum angular resolution, four-edge decoding must be used to read both the rising and falling edges. For instance an angular resolution of up to 0.045° can then be achieved with an encoder disk having 2000 increments.

Speed measurement*:

Encoder disk with 2000 increments:	≤ 3 000 min ⁻¹
Encoder disk with 1024 increments:	≤ 6 000 rpm
Encoder disk with 400 increments:	≤ 15 000 rpm
Encoder disk with 240 increments:	≤ 25 000 rpm

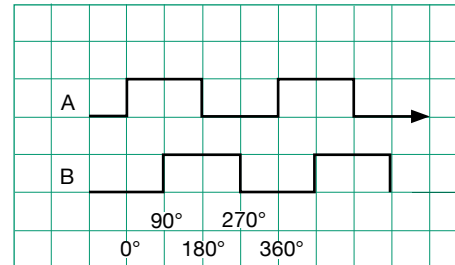

* Not all angular displacement / speed options are available for every measurement range.

	from 0 ... 0.02 N·m to 0 ... 2 N·m	from 0 ... 5 N·m to 0 ... 200 N·m	from 0 ... 500 N·m to 0 ... 1000 N·m	Order Code
2000 Incr.	-	yes	-	see page 6 "Order Code"
1024 Incr.	yes	yes	yes	
400 Incr.	yes	yes	-	
240 Incr.	yes	-	-	

Accessory metal bellow coupling series 8690



Metal bellow couplings for optimum compensation of misalignments

For optimum compensation of misalignment we recommend torsionally free metal bellow couplings. They are characterized by their excellent torsional stiffness during torque load and their low restoring forces.

The compensation of misalignment is beside torque transmission the second essential function of a coupling. Generally, misalignments are classed in three categories.

	Axial misalignment This is change in length along the longitudinal axis of the drive shafts relative to each other.
	Angular misalignment This misalignment is caused by assembly related offsets of the drive shaft to the output shaft.
	Lateral misalignment This misalignment is a parallel offset of both shafts.

For further information please see accessories data sheet.

Accessory mounting block model 8661-Z00X

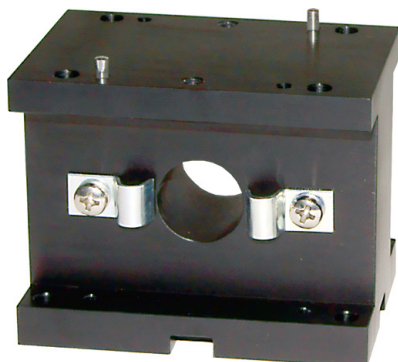

If the sensor needs to be replaced, the locating pin speeds up replacement, avoiding the need for laborious realignment. This can be useful especially when the sensor is only used occasionally in the load path.

The mounting block has a central hole and special design allowing a range of options for reliable cable attachment. Two clips ensure the sensor is fixed securely.

For further information please see accessories data sheet.

Technical data

Electrical values

Rated supply voltage range U_b :	10 ... 30 V DC
DC power consumption (without option):	approx. 2 W
Output voltage at \pm rated torque (sensitivity):	± 10 V
Output impedance:	1 k Ω
Insulation resistance:	> 5 M Ω
Refresh rate:	400 measurements/sec. optional: 1000 measurements/sec.
Ripple:	< 50 mV
Calibration signal:	10.00 V DC
Drive signal (pin K):	10 ... 30 V DC

Electrical connection

Standard sensor:	12 pins connector art. 9940
USB sensor (option):	Mini USB with screwing
Power pack:	Plug diameter 5.7 mm, center pin 2.0 mm (Supply and measuring channel are galvanically isolated)

Speed/angular displacement measurement (option)*

Output without external circuit:	TTL level
Output with external circuit:	Open Collector
Internal pull-up resistor:	2 k Ω (5 V level)
External circuit (Open Collector):	$U_{max} = 30$ V / $I_{max} = 30$ mA
Speed/angular displacement measurement:	
Encoder disk	2000 increments
Encoder disk	1024 increments
Encoder disk	400 increments
Encoder disk	240 increments

*Please note: Not all angular displacement / speed options are available for every measurement range. For more information, see page 5.

Environmental conditions

Nominal and operating temperature range: 0 °C ... 60 °C

	Standard sensor	2nd meas. range dual range sensor
Effect of temperature on the zero signal	± 0.015 % F.S./K	± 0.03 % F.S./K
Effect of temperature on the sensitivity	± 0.01 % F.S./K	± 0.02 % F.S./K

Mechanical values

	Standard sensor	dual range sensor
Relative linearity deviation:		
Measuring range 0.02 to 0.05 N·m	< ± 0.1 % F.S.	< ± 0.1 % F.S.
Measuring range 0.1 to 1000 N·m	< ± 0.05 % F.S.	< ± 0.1 % F.S.
Relative reversal error:	< 0.1 % F.S.	< 0.2 % F.S.
Relative tolerance of the sensitivity	± 0.1 % F.S.	± 0.2 % F.S.
Max. operating torque	200 % of rated torque	150 % of rated torque

Failure torque:	300 % of rated torque
Alternating load:	up to 70 % of rated torque
Material:	
Housing	anodized aluminium
shaft ≤ 0.2 N·m, aluminium measuring shaft,	shaft ends made of stainless steel 1.4542
shaft ≥ 0.5 N·m measuring shaft made of stainless steel	1.4542
Degree of protection to EN 60529:	IP40
Weight:	see table 2/3
Fixing method:	see dimensional drawing page 2

Mounting Instructions

- Make sure that the connecting shaft is exactly aligned.
- Suitable couplings should be used to avoid strain resulting from parallel or angular offset between the shafts.
- Do not exceed permissible axial and radial forces (see table 2) during installation or operation.
- For detailed installation information, please refer to our operating manual (www.burster.com).

Accessories

12 pin mating connector (supplied with device)	9940
12 pin mating connector, 90°	9900-V539
Connecting cable, (torque and rotational angle/speed), length 3 m, one end open	99540-000F-0520030
Connecting cable, (torque and rotational angle/speed), length 3 m, one end open, plug with 90° outlet	99539-000F-0520030
Connecting cable, length 3 m, from 8661 without angle/speed measuring option	
to 9163 of housing	99209-540E-0160030
to 9206-V3xxxx and 9311	99209-540J-0090030
Connecting cable, length 3 m, 8661 to DIGIFORCE® 9307 combined channel D (option channel)	99163-540A-0150030
Adapter cable to DIGIFORCE® 9307 standard channel A/B and C (usable only in connection with type 99163-540A-015xxxx)	99209-215A-0090004
Power pack for external supply	8600-Z010
Mounting block (see page 5)	
measurement range 0 ... 0,02 N·m up to 0 ... 2 N·m	8661-Z001
measurement range 0 ... 5 N·m up to 0 ... 20 N·m	8661-Z002
measurement range 0 ... 50 N·m up to 0 ... 200 N·m	8661-Z003
measurement range 0 ... 500 N·m up to 0 ... 1000 N·m	8661-Z004
Couplings	Series 8690
Display and evaluation instruments	
Torque	e.g. SENSORMASTER 9163
Torque and angle	e.g. DIGIFORCE® 9307 see product section 9

Order Code

Torque sensor	8661-XXXX-V	<input type="checkbox"/>	<input type="checkbox"/>	<input type="checkbox"/>	<input type="checkbox"/>
Standard sensor	0				
Sensor with dual range 1:10	1				
Sensor with dual range 1:5	2				
Sensor with dual range 1:4	3				
Without angle/speed measurement	0				
Angle measurement 400 increments / Speed measurement	1				
Angle measurement 1024 increments / Speed measurement	2				
Angle measurement 240 increments / Speed measurement	3				
Angle measurement 2000 increments / Speed measurement	4				
Output voltage 0 ... ± 10 V	0				
USB interface	1				
Output voltage 0 ... ± 5 V	2				
Round shaft ends	0				
Shaft ends with keyway (Keyway to DIN 6885, Bl. 1)	2				

Order Information

8661 with 100 N·m measuring range, with high-resolution angular displacement measurement, 1024 increments. Option: 2nd measuring range 0 ... 20 N·m with USB interface including measurement and evaluation software 8661-P001 **8661-5100-V2210**

Manufacturer Calibration Certificate (WKS)

Calibration of a sensor or a measuring chain, clockwise and/or counterclockwise torque in 20 % steps, increasing and decreasing.